

## Scheme of the sports beam

The upper plane of the beam and steps is not painted.

The beam racks must be without sharp corners and protrusions.

Racks are recommended to be collapsible, which allows you to change the height of the apparatus for competitions among athletes of different age groups. See the detailed description of design features in clause 5.2.5. of the Rules.

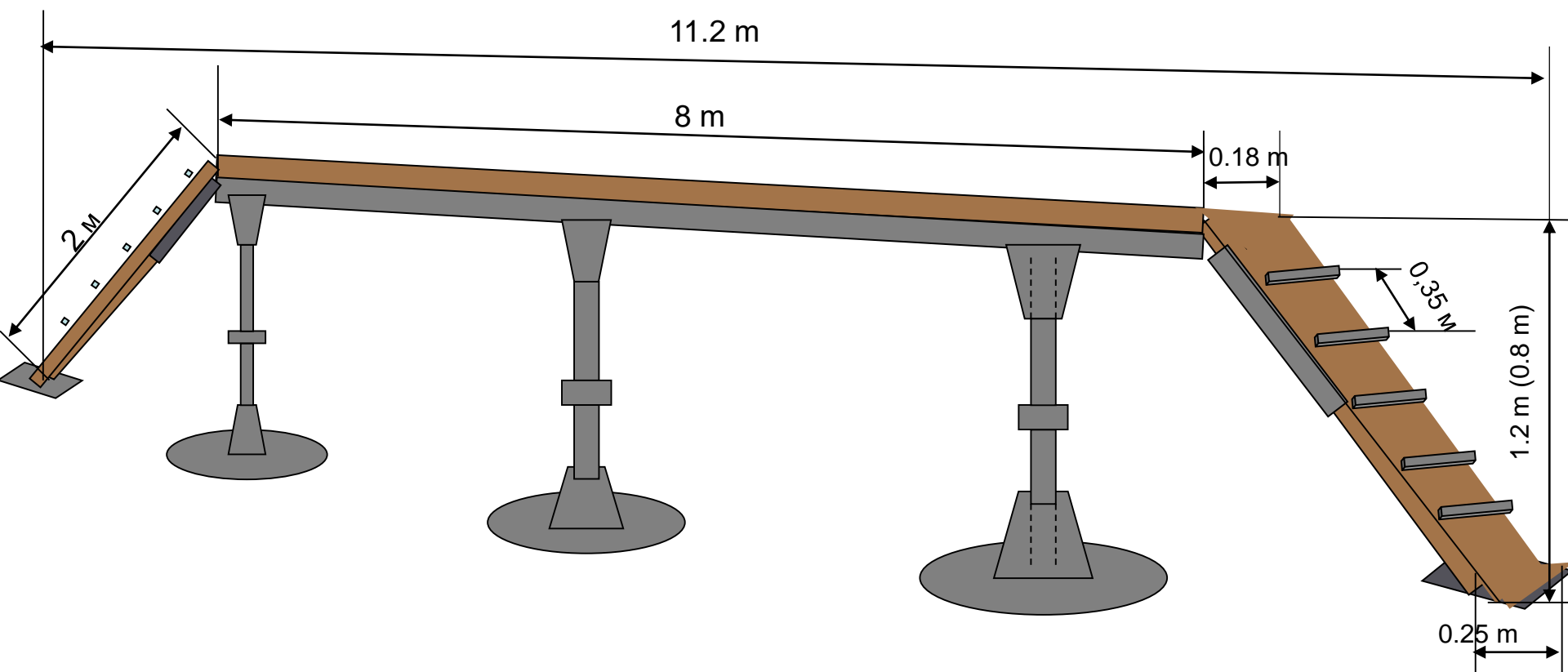

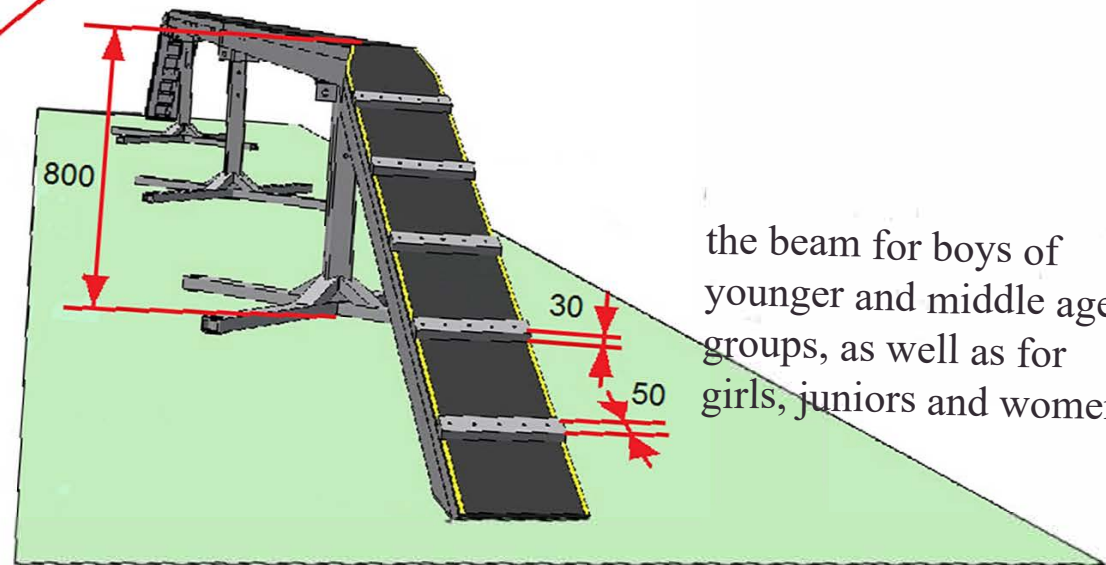
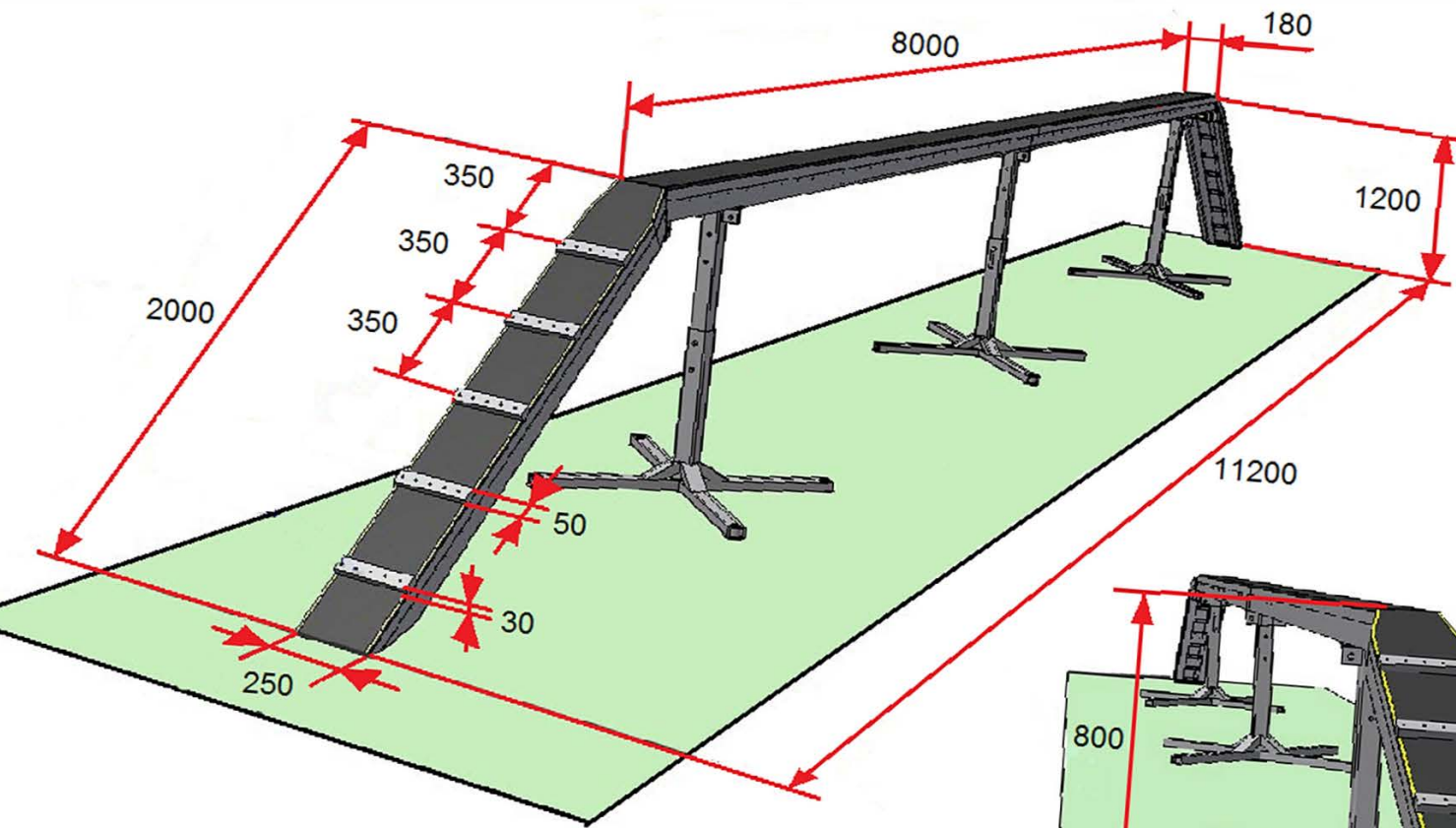

the beam for boys of younger and middle age groups, as well as for girls, juniors and women